

Syllabus

Cambridge O Level Computer Studies

Syllabus code 7010

For examination in June and November 2013



UNIVERSITY *of* CAMBRIDGE
International Examinations

Contents

Cambridge O Level Computer Studies Syllabus code 7010

1. Introduction	2
1.1 Why choose Cambridge?	
1.2 Why choose Cambridge O Level Computer Studies?	
1.3 How can I find out more?	
2. Assessment at a glance	4
3. Syllabus aims and objectives	6
3.1 Aims	
3.2 Scheme of assessment	
3.3 Assessment objectives and their weighting in the exam papers	
4. Curriculum content	11
Section 1: Applications of computers and their social and economic implications	
Section 2: System life cycle	
Section 3: Problem solution including algorithm design, programming techniques and logic gates	
Section 4: Generic software and the organisation of data	
Section 5: Hardware, systems and communications	
Section 6: Topics to be covered in Paper 3 – Alternative to Coursework	
5. Appendix	30
5.1 Notes for the guidance of teachers	
5.2 Forms	
5.3 Assessment criteria for Coursework (school-based assessment)	
6. Additional information	41
6.1 Guided learning hours	
6.2 Recommended prior learning	
6.3 Progression	
6.4 Component codes	
6.5 Grading and reporting	
6.6 Resources	

1. Introduction

1.1 Why choose Cambridge?

University of Cambridge International Examinations (CIE) is the world's largest provider of international qualifications. Around 1.5 million students from 150 countries enter Cambridge examinations every year. What makes educators around the world choose Cambridge?

Developed for an international audience

International O Levels have been designed specially for an international audience and are sensitive to the needs of different countries. These qualifications are designed for students whose first language may not be English and this is acknowledged throughout the examination process. The curriculum also allows teaching to be placed in a localised context, making it relevant in varying regions.

Recognition

Cambridge O Levels are internationally recognised by schools, universities and employers as equivalent to UK GCSE. They are excellent preparation for A/AS Level, the Advanced International Certificate of Education (AICE), US Advanced Placement Programme and the International Baccalaureate (IB) Diploma. CIE is accredited by the UK Government regulator, the Office of the Qualifications and Examinations Regulator (Ofqual). Learn more at www.cie.org.uk/recognition.

Support

CIE provides a world-class support service for teachers and exams officers. We offer a wide range of teacher materials to Centres, plus teacher training (online and face-to-face) and student support materials. Exams officers can trust in reliable, efficient administration of exams entry and excellent, personal support from CIE Customer Services. Learn more at www.cie.org.uk/teachers.

Excellence in education

Cambridge qualifications develop successful students. They build not only understanding and knowledge required for progression, but also learning and thinking skills that help students become independent learners and equip them for life.

Not-for-profit, part of the University of Cambridge

CIE is part of Cambridge Assessment, a not-for-profit organisation and part of the University of Cambridge. The needs of teachers and learners are at the core of what we do. CIE invests constantly in improving its qualifications and services. We draw upon education research in developing our qualifications.

1. Introduction

1.2 Why choose Cambridge O Level Computer Studies?

International O Levels are established qualifications that keep pace with educational developments and trends. The International O Level curriculum places emphasis on broad and balanced study across a wide range of subject areas. The curriculum is structured so that candidates attain both practical skills and theoretical knowledge.

Cambridge O Level Computer Studies is accepted by universities and employers as proof of ability and understanding. The Cambridge O Level Computer Studies syllabus encourages candidates to develop lifelong knowledge and skills, including:

- confidence in the use of computers
- an appreciation of the broad range of computer applications
- a balanced understanding of the power and versatility of the computer and the benefits of its use alongside its limitations and potential disadvantages.

Cambridge O Level Computer Studies is an ideal foundation for further study at A Level, and the skills learnt can also be used in other areas of study and in everyday life.

CIE also offers Cambridge IGCSE and International A & AS Levels for further study in both Computing as well as other technology subjects. See www.cie.org.uk for a full list of the qualifications you can take.

1.3 How can I find out more?

If you are already a Cambridge Centre

You can make entries for this qualification through your usual channels, e.g. your regional representative, the British Council or CIE Direct. If you have any queries, please contact us at international@cie.org.uk.

If you are not a Cambridge Centre

You can find out how your organisation can become a Cambridge Centre. Email either your local British Council representative or CIE at international@cie.org.uk. Learn more about the benefits of becoming a Cambridge Centre at www.cie.org.uk.

2. Assessment at a glance

Cambridge O Level Computer Studies Syllabus code 7010

Candidates take Paper 1, and either Paper 2 or Paper 3. Candidates must be entered for one of the following options:

- Option 1: Paper 1 and Paper 2
- Option 2: Paper 1 and Paper 3

Candidates take:	
Paper 1: Theoretical paper	2 hours 30 minutes
This written paper contains short-answer and structured questions. There is no choice of questions.	
75% of total marks	

And either:	Or:
Paper 2: Coursework (school-based assessment)	Paper 3: Alternative to coursework 1 hour 30 minutes
This is a single piece of coursework of a complex nature, which involves the use of a computer to solve a specific problem. Candidates do the coursework over an extended period. The coursework enables candidates to use their skills and experience gained during the course to analyse, design, implement, test and evaluate the solution to a problem.	This written paper contains short-answer and structured questions. There is no choice of questions.
25% of total marks	25% of total marks

2. Assessment at a glance

Availability

This syllabus is examined in the May/June examination session and the October/November examination session.

This syllabus is available to private candidates.

International O levels are available to Centres in Administrative Zones 3, 4 and 5. Centres in Administrative Zones 1, 2 or 6 wishing to enter candidates for International O Level examinations should contact CIE Customer Services.

Combining this with other syllabuses

Candidates can combine this syllabus in an examination session with any other CIE syllabus, except:

- syllabuses with the same title at the same level
- 0420 IGCSE Computer Studies

Please note that IGCSE, Cambridge International Level 1/Level 2 Certificates and O Level syllabuses are at the same level.

3. Syllabus aims and objectives

3.1 Aims

The aims of the Cambridge O Level Computer Studies syllabus are to enable candidates to:

- develop an appreciation of the range and power of computer applications
- foster an interest in, enjoyment of, and confidence in the use of computing
- develop the ability to solve problems using computing techniques
- develop an awareness of the place of computing in society and issues computing raises in society
- gain a firm understanding of the basic techniques and knowledge required for computing applications
- develop a desire to use computers within other interests

3.2 Scheme of assessment

All candidates need to demonstrate basic levels of knowledge and understanding. To do this, they need to recall information and either apply that information or explain it. All candidates also need to demonstrate some level of practical skill through the project or the alternative to coursework paper. This will require them to show their ability to comprehend, analyse, explain, synthesise and justify, to varying degrees, information and situations which should be broadly familiar to candidates.

Paper 1

This is a compulsory question paper, consisting of short-answer and structured questions. Candidates must answer all the questions.

Paper 2: Coursework (school-based assessment)

The purpose of this project is to allow candidates to demonstrate their ability to undertake a complex piece of work, which is a computer-based solution to a significant problem, and to complete the solution and present their results. A complex piece of work is one which involves one of the following:

- integrating components of two generic application packages to form a single solution
- using some of the more advanced functionalities of a single application package
- using modules and file handling in a coded solution.

In all cases, candidates must fully document the solution.

Teachers assess the coursework, and CIE moderates a proportion of the work. Teachers must get written approval from CIE before they begin school-based assessment. To get approval, teachers have to satisfy CIE requirements concerning marking and internal moderation of coursework. CIE offers schools in-service training opportunities and Coursework Training Handbooks for teachers who do not meet these requirements.

3. Syllabus aims and objectives

Teachers award marks for the following skills:

- Analysis 11 marks
- Design 14 marks
- Implementation 8 marks
- Testing 7 marks
- Documentation 5 marks
- Evaluation 5 marks
- TOTAL 50 marks

Further information on Coursework projects and guidance for their assessment appears in 'Notes for the guidance of teachers' section in the Appendix.

Paper 3: Alternative to Coursework

This paper consists of short-answer and structured questions which refer to a given scenario. Candidates must answer all the questions. There is a maximum of 60 marks for this paper, but the actual weighting will be 25% to give it the same status as Paper 2 (Coursework).

The content of Paper 3 is an alternative to actual coursework. The topics covered are very similar to Paper 2 and also to section 2 of Paper 1 (system life cycle). Consequently, section 2 is tested at a very superficial level in Paper 1 and in much more detail in Papers 2 and 3.

To study the syllabus correctly, Centres should choose a number of typical applications and go through the syllabus items against each application. The simpler applications (which involve a simple database for example) should include the candidates developing a computer system to replace the manual (usually paper-based) system – each stage of the development is assessed against the syllabus items. The more complex applications will require a desk-top exercise.

Examples of simple applications could include:

- monthly expenditure using a spreadsheet
- a simple hotel booking system (database or spreadsheet)
- a simple airline booking system (database or spreadsheet)
- a simple stock control system (e.g. small shop selling CDs)
- route planning for a company that has a maximum of 10 routes

There are many more examples to choose from but the above would allow candidates to use all of the tools outlined in the syllabus and prepare them for the more complex applications which they could only study as a desk-top exercise or obtain information from other sources which describe how the new system was developed.

3. Syllabus aims and objectives

Examples of more complex applications include:

- automatic stock control systems
- a car parts system
- library systems
- control systems (e.g. chemical plants)
- holiday booking company

There are many more examples to choose from but the above would allow candidates to use all of the tools outlined in the syllabus and prepare them for the scenarios chosen in the actual examination paper.

Centres should spend approximately 25% of the total time studying this part of the syllabus and should aim to include computer-based assignments as part of the overall study. Centres can choose how they do this (since access to a computer system is not essential for option 2) but they should try to use computer facilities at some stage when doing Paper 3 topics and topics from sections 2 and 3 of Paper 1.

The syllabus content of Paper 3 covers essentially the system life cycle and it mirrors good practice on Paper 2 (coursework). Centres should study the topics in the Paper 3 syllabus first of all and then gradually apply their learning to increasingly difficult scenarios. The aim is for candidates to go through two or three scenarios on their own once they are comfortable with the techniques. This should prepare them for the type of questions in Paper 3.

The rest of the syllabus covers general flowcharting and pseudocode techniques. This includes dry running of algorithms and an understanding of how to test a given piece of code/flowchart. Centres also need to cover the impact of computerised systems, e.g. once a system has been developed it becomes possible to make it available, for example, on a website. Candidates need to understand how this affects the system (e.g. development of a website), the need for training and the many advantages this gives to the end user and website owner.

The scenario question may include more general questions on developing computer systems as outlined above. Candidates will gain much of this knowledge as they progress through the Paper 3 and Paper 1 syllabus items. These general questions will include:

- doing a dry run of a flowchart or pseudocode section (using trace tables)
- the impact of adopting a computerised system (e.g. websites) and how this changes the application (e.g. Internet-based sales and features found on a typical website)
- anything non-specific from all items in the syllabus (e.g. what is generally found in technical documentation)

3. Syllabus aims and objectives

3.3 Assessment objectives and their weighting in the exam papers

There are three assessment objectives in Cambridge O Level Computer Studies:

A Knowledge and understanding

Candidates should be able to demonstrate knowledge and understanding of computing, in relation to:

- the range and scope of information processing applications
- the effects of the use of computers, both practical and social
- the range of equipment, tools and techniques used to solve problems
- the functions of the main hardware and software components of information-processing systems
- appropriate terminology

B Problem-solving and realisation

Candidates should be able to:

- identify problems within the field of information processing
- analyse problems by considering relevant functional, practical, human and economic factors
- draw up specifications for the computer-based solutions of problems
- select from a range of resources those which are most suitable for solving problems
- develop solutions using appropriate methods
- implement solutions using equipment, tools and techniques sensibly
- test, evaluate and refine solutions systematically
- document solutions to problems

C Communication

Candidates should be able to:

- interpret and organise information
- recognise and present information in a variety of forms
- communicate in appropriate ways information about applications of computers, problems and their solutions

3. Syllabus aims and objectives

Assessment objective	Paper 1	Papers 2 or 3	Overall
Knowledge and understanding	30%	5%	35%
Problem-solving and realisation	20%	15%	35%
Communication	25%	5%	30%
Total	75%	25%	100%

4. Curriculum content

Centres should read this syllabus as an integrated whole and not as a progression. The sections of the syllabus overlap and interrelate and the order of the sections reflects a top-down view of the subject: a study of the applications of computers and the effects of their use is supported by a study of the design processes, methods and mechanisms which underlie such applications.

The sections of the syllabus are:

- 1 Applications of computers and their social and economic implications
- 2 System life cycle
- 3 Problem solution, including algorithm design, programming concepts and logic gates
- 4 Generic software and the organisation of data
- 5 Hardware, systems and communications
- 6 Topics to be covered in Paper 3: Alternative to Coursework.

Each syllabus section contains a number of subsections, and there are descriptions of aims for each section and objectives for each subsection. The content of the syllabus is in two columns, with a list of topics on the left and notes on the topics on the right. Some topics have no notes while some others have extended notes. **The absence, brevity or length of the notes does not indicate the weighting of the topic.** Instead this relates to whether or not there are suitable, widely available sources of clear and unambiguous information on the topic elsewhere. Where the notes contain definitions of terms, the definitions are for the purposes of the syllabus; they are not necessarily universal definitions.

The purpose of this syllabus is not to show how to organise a course. However, here is a suggestion of a possible course structure, which may be helpful to some Centres, although it is not meant to be prescriptive.

A successful course based on this syllabus could start with a study of a simple application, including topics from throughout the syllabus which relate to that application. This could be repeated with other increasingly complex applications from a variety of areas. Within this overall structure, candidates would need to study particular topics in the syllabus in more detail, but, as far as possible, topics could be studied in the context of their application. In parallel with these studies, there would be practical work designed to build upon and illustrate the applications and topics that candidates are studying.

When considering a problem that may be solved using computers, candidates must learn to analyse the problem first to establish the desired outcome and the information requirements. This is followed by the design of a suitable overall system. Then candidates need to be able to specify parts of the system and the interactions between the parts, in detail, and to select an appropriate form of solution for each of these parts. In order to implement the solutions effectively, they need to choose suitable data organisations, algorithms, software and hardware components and use appropriate tools and techniques. Some understanding of the underlying system software and architecture assists in the sensible and efficient uses of resources in the implementation of solutions.

4. Curriculum content

Section 1: Applications of computers and their social and economic implications

The aim of this section of the syllabus is to cover as broad a range of computer applications as possible, so as to provide an understanding of the power and versatility of the computer and the benefits of its use, and also its limitations and the problems and potential disadvantages of its use.

1.1 The range and scope of computer applications

Candidates should be able to demonstrate knowledge and understanding of a wide variety of computer applications. They do not need to have specific knowledge of every kind of application, but they should be able to comment sensibly on any suggested application and make use of specific relevant examples for illustration.

1.1.1 General application areas

The range of computer applications is vast. Candidates can achieve an awareness of this range and of the nature of a variety of application areas through a general study of a number of applications of different kinds. The relevant aspects of any application include the following:

- 1 The purpose of the application
- 2 The required outcome
- 3 The overall system design, including both the computerised and the non-computerised parts of the application
- 4 The necessary inputs to the system and the means by which any data is captured
- 5 The overall organisation and processing of the data within the system
- 6 The use and organisation of the major software and hardware components of the system
- 7 The need for recovery in the event of a system failure
- 8 The interface between the system and its users
- 9 The effectiveness of the system in practice
- 10 The effects of the application on individuals and organisations.

There are many examples in each application area and some are listed below. Candidates should study a varied sample of these.

4. Curriculum content

1.1.2 Communication and information systems, online services, remote databases

Examples studied should include:

- electronic mail (email)
- video-conferencing (e.g. the reasons for increased use in recent years, hardware and software requirements, positive environmental aspects of such systems)
- digital telephone facilities
- information retrieval and database systems
- office automation (e.g. use of word processors, electronic filing, databases, the need to learn new skills)
- library systems (e.g. files containing book details and borrower's details, automatic reminders, use of barcodes to track books and identify customers)
- multimedia (e.g. use of sound, animation and video to help in education/training, producing presentations)
- e-commerce (e.g. online banking, credit card purchases)
- wireless technology (e.g. security aspects, allows no trailing wires)
- broadband versus dial-up modems
- virtual reality applications (e.g. views inside a house, kitchen design)

1.1.3 Commercial and general data processing

Examples studied should include:

- banking systems (e.g. cheque processing, updating of accounts, stages that occur when purchases are made using a bank account)
- hospitals (e.g. patient records, need to update records regularly, hospital administration)
- personnel records (e.g. what would be stored, use of databases, need to keep up-to-date, how these link into other areas such as payroll)
- automatic stock control and order processing (e.g. use of barcodes in supermarket stock control)

4. Curriculum content

1.1.4 Industrial, technical and scientific uses

Examples studied should include:

- weather forecasting (e.g. how data is gathered and processed, how information is conveyed, predictions based on new data and existing data)
- computer aided design (e.g. features of CAD, banks of “parts”, ability to do costings, applications such as electronic circuit design)
- simulation and modelling (e.g. how data is gathered for a model, how predictions are made, why modelling is done, use of the model in applying to real applications)
- use of virtual reality (e.g. designing new chemical/nuclear plants, ability to “see inside” plants using special devices, safety applications)
- training (e.g. airline pilots – advantages of doing this, what hardware is used, why training simulators are used)

1.1.5 Monitoring and control systems

Examples studied should include:

- monitoring hospital patients (how equipment monitors vital signs, how the system knows when to alarm doctors)
- chemical/nuclear plants (using sensors to monitor and control the plants, what is monitored, how plant status is relayed to operators, why plants are controlled by computers)
- traffic control (how models/simulators are used to set traffic light timings, types of sensors used to gather data, how system “decides” timing of lights)

1.1.6 Automation and robotics

Examples studied should include:

- domestic equipment (e.g. use of microprocessors to control microwave ovens, etc., intelligent cookers that use barcodes to automatically set cooking times/temperatures)
- navigation systems (e.g. satellite navigation used in ships, aeroplanes and cars (global positioning), directions given by voice synthesis, benefits and drawbacks of these systems)
- industrial robots (e.g. in car manufacturing and other automated processes, advantages in terms of quality control and the environment, affects on work force)
- use of CCTV (e.g. cameras used in surveillance, automatic warning of intruders, use of sensors to control camera)

4. Curriculum content

1.1.7 Expert systems

Examples studied should include:

- mineral prospecting
- medical diagnosis
- diagnostics (e.g. car engines, electronic devices)

Candidates should be aware of the following aspects of expert systems:

- how they are created
- how they function (role of inference engine, rule base, knowledge base and human-machine interface)
- why and where they are used to great effect

1.1.8 Education and training, entertainment

Examples studied should include:

- computer-based learning (e.g. interactive learning and assessment)
- applications in music (e.g. how music is produced and generated using computers, teaching how to play musical instruments through computer systems/electronic interfaces)
- computer graphics in animation for TV and film (e.g. how cartoons/animation is produced, special effects, synchronising speech with animation, superimposing humans into cartoons)
- virtual reality in training (e.g. use in dentistry, learning to operate chemical/nuclear plants)

1.1.9 Use of the Internet

- designing Internet sites (e.g. web page features customers expect to see when ordering online, obtaining information, online banking and e-commerce)
- use of search engines (e.g. how to refine your searches, features of search engines)
- security (e.g. how credit card protection features are built in (e.g. encryption, use of smart card slots in keyboards), people's fear of the Internet)
- society (e.g. affects on society of using Internet-based shopping, information retrieval and education systems)
- other applications (e.g. ability to use live satellite maps, interactive maps that combine traditional maps with satellite images, other modern applications)
- use of intranets (e.g. many large companies adopt intranets as well as Internet access, the differences between intranets and the Internet)

4. Curriculum content

1.2 The social and economic implications of the use of computers

In addition to knowledge about applications, candidates should be able to demonstrate a broad knowledge of the economic reasons for using computers and the effects of their use across a range of application areas. They should be able to formulate a reasoned view of the potential effects of any suggested application or development and to show their critical abilities in balancing the advantages and disadvantages of a computerised system.

1.2.1 Social and economic effects on people and organisations associated directly with the application, on other individuals and organisations, and on society in general

The social and economic effects of the use of computers should be discussed in the context of particular computer applications, with any general principles being based upon real examples. For example, the de-skilling brought about through the replacement of skilled and semi-skilled labour by microprocessor-controlled systems in manufacturing; the ability to site operations anywhere in the world, e.g. call centres, online retailing; the benefits to unions and to management of “new technology” agreements leading to greater productivity and better working conditions.

Candidates should consider the economic reasons for using computerised systems, the changes to existing methods and services and the changes to the working environment because computerised systems are used. The applications discussed in Section 1.1 should be used as a basis for this study.

Candidates should consider the health and safety aspects of using computers in the workplace.

1.2.2 Changes in employment, re-training

Candidates should identify the need for re-training of staff as existing packages are upgraded and new ones are published. This includes the use of multimedia training packages for individual use on CD-ROM or DVD.

1.2.3 Privacy and integrity of data

To ensure data is kept safe from hackers (e.g. by passwords, firewalls) and data is protected from corruption, etc.

1.2.4 Data protection legislation

For example the features expected in a data protection act, such as data must be up-to-date, data must be accurate, data must be obtained lawfully.

1.2.5 Security and reliability; the consequences of system failure

The requirements for security and reliability vary considerably depending on the nature of the application. For example, a failure during a batch update of a sequential master file is irritating and will cause delay, whereas a failure in an air traffic control system could well have catastrophic results.

4. Curriculum content

1.2.6 Hacking and other computer crime

Computer crime includes activities such as the cracking of ineffective security systems in order to gain unauthorised access to commercially sensitive or confidential personal files, and fraud through the improper transfer of funds from one account to another. Computer criminals may work within the organisation or may be outsiders. Measures taken to combat computer crime include physical security, development of complex security codes and systems, encryption of sensitive data, and monitoring of all attempts to access the system, whether successful or not. Modern security systems include the use of smart cards (which are slotted into the side of a keyboard and prevent access unless the PIN typed in matches the one stored on the chip) and other electronic devices (e.g. modern passports and security passes contain a chip and/or loop circuit recognised by an electronic reading device).

1.2.7 Computer viruses

What is a virus, the affect of a virus on a computer system, how to guard against viruses (e.g. use of appropriate software, firewalls).

1.2.8 Internet security and usage

Potential problems with Internet use in the form of, for example:

- viruses
- hacking
- spam
- spyware
- cookies
- phishing
- pharming

Modern developments in the use of the Internet, for example:

- wikis
- social networking
- blogs
- digital media sharing websites
- web browsers
- ISPs
- tagging
- podcasts
- bit streaming

4. Curriculum content

Section 2: System life cycle

The aim of this section of the syllabus is to cover the main principles of the system life cycle which include aspects of fact finding, feasibility study, analysis, design, implementation, testing documentation, methods of changeover, evaluation and maintenance. This is achieved partly through the study of computer applications, in particular the methods by which a problem has been analysed to lead to a successful solution for the user, and partly through practical work.

2.1 Systems analysis and design

Candidates should be able to describe the main steps involved in systems analysis and they should be able to use charts and diagrams. They should be able to apply the principles of systems analysis in their coursework projects and/or alternative to coursework studies.

A variety of problems/solutions should be examined beginning with the relatively simple (e.g. keeping a record of pocket money – how to go from a paper-based record to using a spreadsheet) to the more complex (e.g. an automatic stock control system replacing a paper-based system in a supermarket, for example).

Candidates should be aware of what is required at each stage of the system life cycle. The use of various diagrams (e.g. top-down design, systems flowcharts, dataflow diagrams) is essential when studying actual examples.

- | | |
|-------------------------|---------------------------------------------------------------------------------------------------------------|
| 2.1.1 Fact finding | Candidates should know the methods used in fact finding (and which method is appropriate for an application). |
| 2.1.2 Feasibility study | Candidates should understand what forms a feasibility study. |
| 2.1.3 Analysis | Candidates should be aware of what forms the analysis stage. |
| 2.1.4 Design | Candidates should be aware of what forms the design stage. |

2.2 Implementation, evaluation and maintenance

- | | |
|----------------------|-------------------------------------------------------------------------------------------------------------------------------------|
| 2.2.1 Implementation | Candidates should be able to develop solutions using appropriate methods. |
| 2.2.2 Testing | Candidates need to be aware of testing strategies and should be capable of choosing appropriate test data. |
| 2.2.3 Documentation | Candidates should know what items are included in a user guide and in technical documentation. |
| 2.2.4 Changeover | Candidates should understand appropriate methods for changeover (including the advantages and disadvantages of the common methods). |
| 2.2.5 Evaluation | Candidates need to be aware of how a system is evaluated. |
| 2.2.6 Maintenance | Candidates need to be aware of how a system is maintained. |

4. Curriculum content

Section 3: Problem solution including algorithm design, programming techniques and logic gates

The aim of this section of the syllabus is to cover the design, development, implementation, maintenance and review principles, which include techniques and tools relating to the solution to a problem. A study of these topics is reinforced through practical work and illustrated by a consideration of existing problem solutions in computer applications.

3.1 Algorithm design and testing

- | | |
|-------------------------------------|---------------------------------------------------------------------------------------------------------------------------------------------------------------------------------------------------------------------------------------------------------------------------------------------------------------------------------------------------|
| 3.1.1 Make an overall plan | Most of this work should be conducted through the use of practical exercises.
Define the scope of separate modules
Design algorithms which relate clearly to the requirements of the system
Explain algorithms and how they relate to the system
Explain how hardware needs arise from the output required from the system |
| 3.1.2 Algorithm tools | Top-down design, structure diagrams, flowcharts, libraries of procedures and subroutines. |
| 3.1.3 Interpret and test algorithms | Candidates should be able to work out the purpose of an algorithm using dry runs, and to suggest and apply suitable test data.
Candidates should use trace tables to find the value of variables at each stage in an algorithm.
Candidates should be able to identify errors in given algorithms and suggest ways of removing these errors. |

4. Curriculum content

3.2 Programs, representation of algorithms and documentation

Candidates should have experience of representing algorithms as structure diagrams, flowcharts, step sequences and description, and more formally in pseudocode. Candidates should appreciate the main requirements of a programming language, to allow manipulation of data of various types and structures, including control of input and output, and to provide for selection, repetition and subprogram intercommunication. Candidates should have a basic understanding of the functions of interpreters, compilers and assemblers, and an appreciation of the benefits offered by the existence of a range of languages, both high- and low-level.

- 3.2.1 The concept of a program Candidates do not need to code in any particular language but they should be familiar with the concepts of sequence, selection and repetition. They should understand the concepts of totals and counting.
Candidates should be able to produce an algorithm for a given written problem (either written in pseudocode or in the form of a flowchart). They should have the ability to identify errors and suggest corrections in a given piece of pseudocode.
- 3.2.2 High-level languages For example: these are portable, need to be compiled or interpreted, easier to write and debug.
- 3.2.3 Low-level languages For example: machine-specific types of language (machine code or assembly code), why these languages are used.
- 3.2.4 Pseudocode structures
- repeat ... until
 - if ... then ... else ... endif
 - case of otherwise ... endcase
 - while ... do ... endwhile
 - for ... to ... next
 - input and output* (e.g. read, print)
 - totals* (e.g. sum = sum + number)
 - counting* (e.g. count = count + 1)
- 3.2.5 User guide, technical documentation Candidates should be able to distinguish between the documentation that users require and the documentation required by those responsible for improving and maintaining a solution in working order or for developing the solution to meet new needs.

4. Curriculum content

3.3 Logic gates and circuits

Candidates should be aware of the use of logic gates in creating electronic circuits and components. It is useful to use kits available on the market to understand how logic gates work and to build some simple circuits. There are numerous websites, such as www.kpsec.freeuk.com (choose the STUDY section and then the LOGIC GATES option) which help in supplying worked examples.

3.3.1 Basic logic gates

Candidates should be able to understand and define the function of NOT, AND, OR, NAND and NOR logic gates including the binary output produced from all possible binary inputs. They need to be able to draw truth tables and recognise a logic gate from its truth table.

3.3.2 Logic gate symbols

Candidates need to recognise two ways of representing the logic gates:

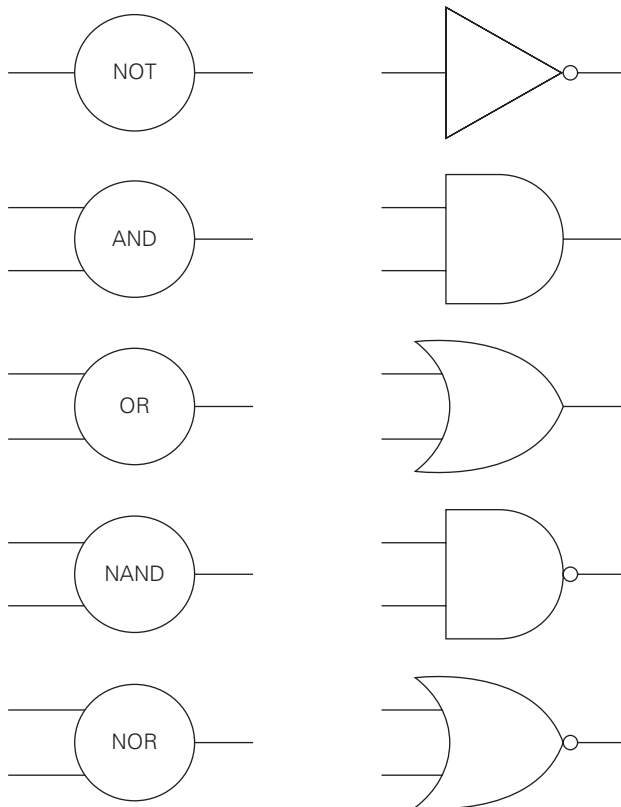

4. Curriculum content

3.3.3 Interpreting simple logic circuits

Candidates should be able to produce truth tables for given logic circuits (maximum of 3 inputs and 6 gates).

a	b	c	output
1	1	1	
1	1	0	
1	0	1	
1	0	0	
0	1	1	
0	1	0	
0	0	1	
0	0	0	

3.3.4 Designing simple logic circuits

Candidates should be able to produce a simple logic circuit from a given written statement (e.g. *if A AND B are on AND if C is on then the lights will be on*).

4. Curriculum content

Section 4: Generic software and the organisation of data

4.1 Generic software packages

The aim of this section is to give candidates a broad overview of generic software packages. These should be experienced through practical work. Although candidates may choose to become expert in the use of a particular package, they only need a general knowledge of the kinds of features typical of generic packages.

Software for word processing, database management, spreadsheets, graphics, communications, multimedia, data-logging, CAD, programming, desktop publishing and web design

Candidates should appreciate ways, including import and export, of using programming, desktop publishing, word processing packages, spreadsheets, databases, graphics packages and information retrieval packages, and show an understanding of the use of graphical user interfaces, communications software (including email), web browsers, search engines and authoring packages (also refer to section 1.2). They should appreciate the advantages and disadvantages of generic packages compared with specially written bespoke software and how packages may be customised by the use of macros. They should be able to explain the use of the tools associated with data-logging.

4.2 Data

Candidates should be aware of the standard methods of data collection, verification and validation, and where it is appropriate to use particular methods.

Candidates should understand that data, particularly data held in files, requires access in different ways depending on the particular application. The medium on which the data is stored, and particularly the way in which it is organised, depend on the requirements for access. Candidates should be familiar with the idea of file ordering and the principles of sorting and merging. They should have experience of sequential file processing and of processing individual records by means of record keys.

4. Curriculum content

4.2.1 The relationship between information and data; the collection of data; methods of ensuring its correctness (including validation and verification and the distinction between these); the coding of data for input; the presentation of useful information from processed data; analogue-to-digital and digital-to-analogue conversions

Candidates should be able to describe and select:

- automatic data capture techniques in a number of applications (e.g. barcodes in automatic stock control systems, OCR/OMR techniques (e.g. use in reading questionnaires), sensors in data logging (also refer to section 5.1))
- data collection methods (e.g. automatic methods as described above, manual inputting via keyboards and touch screens)
- validation techniques (e.g. range checks, type conversion checks). The use of check digits (candidates should be able to understand how check digits are generated and why they are used).
- verification techniques (i.e. methods that can be used such as double entry and visual checks); the uses for verification (e.g. checking password entries)
- ADC and DAC (e.g. how these are used in control and monitoring of processes; refer to section 5.1)

4.2.2 File organisation: different forms of organisation, depending on the data stored and the requirements for processing; processing methods

Candidates should be able to describe:

- the need to process files
- how files are processed
- file maintenance (updating, inserting and deleting data from files as appropriate)

Candidates should be able to select with reasons:

- the appropriate file organisation and processing methods for a particular application.

4.2.3 Data types for numbers, characters, strings, arrays; the need for different data types and structures to represent the data of problems which are being solved using a computer

Candidates should be able to:

- identify the different forms of data and explain how the data is represented for processing with reference to a given problem
- explain the need for different data types and structures and how these relate to the data of the given problem.

4. Curriculum content

Section 5: Hardware, systems and communications

The aim of this section is to draw together the experience of various kinds of hardware and types of processing, and to examine the concepts of operating systems and communications.

5.1 Hardware

5.1.1 Computer, microcomputer, microprocessor, standard input and output devices, broad classes of processor power

Candidates should be able to identify:

- the use of laptop computers (including their differences to desktop PCs)
- the required specification for a laptop (i.e. they should consume little power, run cool, etc.)
- the use of microprocessors in everyday-life objects (e.g. cameras (including CCTV), digital watches, televisions)

Candidates should be able to describe/select:

- suitable input and output devices in relation to the requirements of the application
- the use of specialist input and output devices (e.g. to help disabled people communicate with a computer system, devices to communicate with virtual reality systems)

5.1.2 The functions and characteristics of storage media

Candidates should have a good understanding of the operation of internal memory devices such as RAM, ROM, hard disk.

Candidates should understand the operation and areas of application for traditional external storage media such as CD-ROM, CD-RW and DVD.

Candidates should understand the operation of other memory devices such as:

- USB flash memories
- memory systems used in MP3/4 players
- HD cards in digital cameras
- use of modern devices in storing music and films (e.g. use of hard drive which allows recordings to take place at the same time as playing back files)

5.1.3 The characteristics and performance of a range of peripherals (including control and communication devices)

Candidates should be able to discuss the suitability of different peripherals for various applications.

Candidates should be aware of the role of the mobile telephone in communications systems (this can cover a wide range of topic areas such as Internet access, use as cameras, use as MP3 players, etc.).

4. Curriculum content

Candidates should be aware of the different types of sensor used in a wide variety of control and monitoring applications, such as:

- temperature (e.g. heating systems)
- moisture (e.g. greenhouse applications)
- gas (e.g. environmental monitoring)
- light (e.g. operating automatic doors)
- infra-red (e.g. detecting intruders)

5.2 Systems and communications

5.2.1 The nature of batch, multi-access, real-time transaction processing, multitasking, network and process-control operating systems

A real-time transaction processing system is an online system which processes individual, discrete transactions as they occur, e.g. an airline booking system and an online stock control system. This use of the term real-time differs from its use in a real-time process-control system, which continuously monitors and processes physical quantities sufficiently rapidly to be capable of influencing the sources of data.

5.2.2 The form of interface between the operating system and the user; use of command line and use of graphical user interfaces

5.2.3 Management of files; file directories; folders

The need for and use of facilities to copy, move, list, print files. The use of sub-directories.

5.2.4 Peripheral device control; use of buffers; interrupts and interrupt priorities; polling; handshaking; checksums

For an interrupt system the external device or event interrupts the processor, whereas in a polling system the processor interrogates the device or status register. These two alternative methods have very different processing requirements.

Adding together all of the elements (for example, bytes) of a block produces a single element known as the checksum. This can then be stored with the block and provides a check when the block is transferred.

4. Curriculum content

5.3 Types of system

Candidates should be able to distinguish between the different types of system, to describe what is needed to support them, to explain which is the most suitable for any given application and to discuss the consequent implications for the user. Candidates should be able to describe particular problems in the management of the various types of system, such as conflicting access to common data or critical timing considerations.

- | | |
|--------------------------------|-----------------------------------------------------------------------------------------------------------------------------------------------------------------------------------------------------------------------------------------------------------------------------------------------------------------------------------------------------------------------------------------------------------------------------------------------------------------------------------------------------------------------------------------------------------|
| 5.3.1 Batch processing systems | In broad terms, a batch processing system processes a job without any direct interaction between the job and the user. Typical applications are payroll and billing systems. |
| 5.3.2 Interactive systems | In contrast to the above, an interactive system provides for interaction between the job and the user, which may influence the future course of processing. Such systems may be single-user (for example, a personal computer) or multi-user. Typical applications are word processing and online information retrieval. |
| 5.3.3 Network systems | <p>A network system is one in which processing occurs independently in more than one location, but with shared and controlled access to some common facilities which normally include file storage and information resources.</p> <p>Candidates should be able to describe and compare the topology principles of ring, bus and star networks and also understand the need for local (e.g. intranet) and shared resources and gateways for accessing wide area networks (WANs).</p> |
| 5.3.4 Control systems | In a control system, one or more computers control the operation of some non-computer equipment, usually involving some monitoring and logging of physical quantities, providing some analysis of performance and allowing some user interaction. Feedback is an essential element in most control systems. Timing considerations are often critical and the term real-time control system is sometimes used to indicate this. Control systems are used in applications such as oil-refining, chemical processing and integrated traffic-control systems. |
| 5.3.5 Automated systems | Automated systems are broadly similar to control systems but are dedicated to a particular task, and lack the ability to collect and analyse data and the flexibility to allow for and act on user interaction beyond a very simple level. Examples are the systems found in equipment such as washing machines and cameras. |
| 5.3.6 Multimedia | Candidates should be able to specify minimum hardware and software requirements for multimedia applications, and describe typical features and uses of multimedia systems. |

4. Curriculum content

Section 6: Topics to be covered in Paper 3 – Alternative to Coursework

Introduction

The *Alternative to Coursework* syllabus follows the philosophy of the more traditional coursework (Paper 2) syllabus. Most of the topics described here are already covered by the existing Paper 2; the main difference here is that the topics are assessed via a written paper with a duration of 1 hour 30 minutes.

Stages in the creation of a project

The question paper includes a scenario, i.e. a description of a computer-based sample project. Candidates have to answer questions about this sample project covering some of the topics listed below. Centres receive an outline of the scenario in advance so that candidates can do some research in preparation for the actual examination.

- | | |
|-------------------------------------------------------------------|-------------------------------------------------------------------------------------------------------------------------------------------------------------------------------------------------------------------------------------------------------------------------------------------------------------------------------------------------------------------------------------------------------------------------------------------------------------------------------------------------------------------------------------------------------------------------------------------------------------------------------------------------------------|
| 6.1 The methods used to identify how the existing system operates | Candidates need to understand the general techniques such as observation, questionnaires, interviewing and review of existing documentation together with the reasons for the chosen methods and how they would be carried out. |
| 6.2 Action plans | Candidates need to understand how a project team would ensure the development and final implementation of a new computer-based system to an agreed timescale and to budget. They need to be aware of what tools exist to monitor and track project progress. The more common tools available are Gantt Charts, Critical Path analysis, use of software tools such as project management software, PERT charts, etc. |
| 6.3 Hardware and software | Candidates need to choose the most appropriate hardware and software for a given project. They need to be able to justify their choice. They also need to explain whether “off-the-shelf” software or bespoke software would be better for a given application. |
| 6.4 Flowcharts and pseudocode | Candidates need to be able to draw a systems flowchart to outline each of the stages in the final computerised solution. Use of the standard systems flowchart symbols would be expected. Candidates should be able to recognise the common flowchart symbols and the common pseudocode keywords. Candidates should study the use of pseudocode and normal flowcharts, in particular:
Dry running of an algorithm in either the form of pseudocode or flowchart. Candidates should be able to use trace tables to show the logical steps through an algorithm and be able to show the values of all the variables at each stage in the algorithm. |

4. Curriculum content

- 6.5 Test data for use with algorithms Candidates must be able to
- suggest additional test data for use with the supplied algorithm
 - justify their reasons for choosing the test data and explain what output they would be looking for.
- 6.6 Implementing the new system Candidates should be aware of the various methods used to implement the final system. They should be able to describe the advantages and disadvantages of the various methods and also be able to justify why a particular implementation method has been chosen.
- 6.7 Testing Candidates should be able to produce a testing strategy (e.g. using acceptable (normal), unacceptable (abnormal) and boundary (extreme) data) for the project. They must be able to explain why a certain strategy has been adopted and also what is expected at each stage (e.g. use of data with known outcomes, data to test validation routines, etc.).
- Candidates must also be able to suggest (and justify) appropriate test data to fully test a given system.
- 6.8 Documentation Candidates must be aware of what is required in user guide and technical documentation to accompany the final system.
- 6.9 Evaluation After installing a system it is necessary to evaluate its effectiveness. Candidates need to be aware of how evaluation is carried out and the reasons why it is done.
- 6.10 Advantages and limitations of adopting the new computer-based system Candidates should also be aware of the advantages and the limitations of adopting the new computer-based system. They need to understand how adopting a computer-based system opens up many other possibilities such as an Internet-based website (and the requirements/features of such a website), use of company-wide intranets and computer-based training methods.
- 6.11 Candidates do not need to study a particular programming language for this paper; but they should know how to use and recognise standard pseudocode keywords:
- repeat ... until
 - if ... then ... else ... endif
 - case of ... otherwise ... endcase
 - while ... do ... endwhile
 - for ... to ... next
 - (together with input, output and processing keywords e.g. input x, output "value=" v, count = count + 1)

Any good text book covering computer studies techniques will contain standard flowchart and systems flowchart symbols.

5. Appendix

5.1 Notes for the guidance of teachers

Introduction

The purpose of these notes is to provide assistance for teachers preparing candidates for the Cambridge O Level Computer Studies examination. They contain notes on equipment, facilities and resources and sources of further information. The sections on approaches to practical work and to the project (Paper 2) are particularly detailed.

Equipment and facilities

Computer Studies is a practical subject and the Cambridge O Level syllabus places emphasis on the use of commercial and other major packages and on the applications of computers. Centres must ensure that their equipment and facilities are adequate for candidates to be able to satisfy the requirements of the syllabus. The hardware facilities needed will depend on the number of candidates, but should be sufficient for all candidates to have enough time to become familiar with both systems software and applications packages, and possibly to develop their own software. The software available needs to be sufficient in quality and range to enable candidates to experience a variety of applications of computers in a practical way, as required in the syllabus.

Hardware

Candidates need to have access to a system with direct-access file capability on backing store and hardcopy facilities for both text and graphics.

The principal danger of using microcomputers exclusively is that many candidates gain the impression that all computing is exemplified by the facilities of the microcomputer. Candidates will find it useful to visit such places as retail outlets, libraries, factories, banks and so on, in order to see the need for large computer systems.

Software

Access to a wide variety of software packages is very important. Such software packages should include word processing, spreadsheets, information retrieval/file management systems, desktop publishing and graphics as well as facilities for data-logging.

Candidates should have experience of using systems software and of using utility programs, such as routines for data transfer, sorting, searching and merging.

5. Appendix

Books

Provision of textbooks is difficult as new titles are available all the time. The British Computer Society (BCS) booklists for Centres and colleges lists books which are suitable for use as reference books. Teachers will need to consult several books to cover the whole syllabus adequately. There is a suggested book list on our website. Many schools prefer to have a wide range of reference books rather than a class textbook.

Practical work

Computer Studies is a practical subject and a range of practical exercises should supplement the study of most parts of the syllabus.

It is important that Centres encourage candidates, as early as possible in the course, to develop a systematic approach to practical problem-solving using appropriate resources.

In addition to the practical work which candidates do throughout the course, there is the requirement to present one significant piece of practical work for assessment.

General practical work

Candidates need to learn the techniques of problem-solving. This involves:

- the definition of the problem
- the choice of a method of solution
- the selection of the appropriate hardware and software
- the documentation of the solution.

The definition of the problem should include a description of the organisation for which a problem has been jointly identified, together with a description of that problem.

The method of solution includes:

- the breakdown of the problem into sub-problems
- a description of the processes to be carried out
- the design of the presentation of the results.

It should also take into account

- the implications for human resources
- the resources required which may be standard or purpose-designed hardware
- general or special-purpose application packages or the use of a programming language.

The documentation of the solution is in two parts.

- The first provides technical information about the solution which explains and justifies its design and is sufficient to allow maintenance and development (technical documentation).

5. Appendix

- The second contains general information about this problem and its solution which enables a user to make effective use of the solution (user guide).

Candidates will find it easiest to use a top-down approach. After carefully defining the problem, they can break down the algorithm for its solution into component parts at successively lower levels in small sections known as modules.

Assessed practical work (Paper 2)

Candidates need to present one complex piece of practical work for the purpose of the examination. The weighting given to this work is 25%, therefore this is a very important part of the course. The teacher acts as supervisor of the candidates and must carry out the assessment in accordance with the instructions on the Individual Candidate Record Card. **The submitted project must be the unaided work of each and every candidate.**

In the role of supervisor, the teacher should do the following.

- (a) Help each candidate to choose practical work which is within the candidate's capability and range of interests.

Good project topics are open-ended in the sense that if the work proves to be easier or the candidate more able (and enthusiastic) than the teacher first thought, it can be developed further.

Similarly, if the work proves more difficult or the candidate less able than was first thought, it should be possible to simplify it.

- (b) Ensure that candidates start their documentation as soon as they start the work. The early documentation may need revision as the project proceeds.

- (c) Insist on seeing a written description of the aims of the practical work before it is started.

The teacher should discuss the amount of time that the candidate should spend on each stage, and should tell the candidate (and periodically remind them) of the final date for submission to the teacher.

Teachers should set this date at least one month before the final date when they have to submit assessed practical work to CIE for moderation.

- (d) Closely supervise the work throughout.

Candidates should provide documentation and teachers should regularly inspect it. The teacher may give detailed assistance if necessary, but they must take into consideration the amount of help of this kind when assessing the work. The teacher must include a note about the assistance given in the appropriate place on the Individual Candidate Record Card.

- (e) Encourage candidates to implement a back-up policy.

- (f) Candidates should use a word processor to produce their documentation and include an overall report contents page; failure to do so will result in a loss of marks.

5. Appendix

The mark a candidate can achieve is often linked to the problem definition and therefore teachers should guide candidates in their choice of problem. Teachers must provide on-going support, guidance and supervision during the project. However, if a teacher has to provide excessive help or guidance, the candidate will lose marks: the teacher will decide the level of deduction by taking into account the amount of help given. Excessive help or guidance is when the teacher tells the candidate exactly what to do and the candidate makes no further progress in that particular area. If such help forms part of the normal teaching process then the teacher should not deduct marks. Also if the help enables the candidate to achieve a higher standard without further assistance then the teacher should not deduct marks. However, if a Centre makes a deduction, then the teacher must clearly annotate the reason for the deduction **on the individual assessment form** for that particular candidate, and the candidate's project must be included as part of the sample for moderation.

Teachers should make candidates aware that hardcopy output of results is essential except where this is inappropriate (for example in a control application or some graphical solutions). For projects involving control or graphics, Centres usually find no difficulty in obtaining photographs of the screen or screen dumps; the teacher must authenticate any such photos. If a candidate undertakes hardware control or animated projects, they can submit visual evidence in DVD format.

If candidates use material from magazines or other sources in their projects, they must acknowledge this material. Teachers should ensure that they do this.

Suggestions for practical work

The exact method of solution will be the choice of each candidate but the teacher will need to ensure that they have covered all options during the course. CIE will not recommend the use of any specific programming language; the Centre should choose the language according to the resources available. However, if candidates choose to write their own program then the choice of language must allow them to construct their program using a structured modular approach. Previous experience of candidates' work indicates that the choice of certain projects involving games, quizzes and word processing are unsuitable projects and do not provide the opportunity to achieve high marks. Teachers may find it useful to use the forum to share topics and ideas for project work.

5. Appendix

Moderation

(a) Internal Moderation

Teachers assess the completed projects. If more than one teacher in each Centre is involved in assessment then the Centre must make arrangements for internal moderation to ensure that all teachers are marking to the same standard. The Centre must also moderate the marks for each skill assigned within different teaching groups (e.g. different classes).

(b) External Moderation

CIE carries out external moderation of internal assessment.

Centres complete the Individual Candidate Record Cards and Coursework Assessment Summary Forms, and send them to CIE. The forms must arrive by 30 April for the May/June examination and by 31 October for the November examination.

If there are 10 or fewer candidates entered for a Coursework component, Centres must submit all the Centre-based assessment that contributed to the final mark for that component. If there are more than 10 candidates, then CIE will select a sample of candidates for external moderation. Centres must submit all the Centre-based assessment that contributed to the final mark for that component for these candidates.

The Handbook for Centres and the Administrative Guide for Centres both contain further information about external moderation.

Centres should keep all records and supporting written work until after publication of results.

5.2 Forms

See the following pages for samples of the forms required.

**COMPUTER STUDIES
INDIVIDUAL CANDIDATE RECORD CARD
O LEVEL 2013**

Centre Number					Centre Name							
Candidate Number					Candidate Name						Teaching Group/Set	

Please use the space on the reverse for any comments about the project(s), marking, and help given to the candidate beyond normal supervision. Comments are especially important where the marks awarded differ from what might have been expected on the sole evidence of the submitted material.

Title(s) of Project(s)

	Analysis					Design					Implementation			Testing		Documentation		Evaluation					
	Description of the Problem	Objectives	Description of existing solution	Evaluation of existing solution	Description of other possible solutions	Action plan	Systems Flowchart	Description of method of solution	Hardware	Software	Method of solution related to problem	Accurate method of solution	Programming code	Test strategy	Test results	Technical documentation	User guide	Evaluation	System development	TOTAL	Deduction for teacher assistance	FINAL TOTAL	
Section	1	2	3	4	5	6	7	8	9	10	11	12	13	14	15	16	17	18	19		20		
Max	2	3	2	2	2	3	2	3	3	3	2	3	3	3	4	2	3	3	2	50	10	50	
Mark																							
Page(s)																							

Name of teacher completing this form		Signature		Date				
Name of internal moderator		Signature		Date				

5. Appendix

5.3 Assessment criteria for Coursework (school-based assessment)

ANALYSIS	1 mark	2 marks	3 marks
1. Description of the problem	Brief description of the background to the business or organisation	Description of the background to the business or organisation, together with the nature of the problem to be solved	
2. Objectives (must be stated in relation to the proposed solution)	Objectives listed in general business terms, e.g. to make a process faster, to save time or resources	Objectives listed in computer-related terms, e.g. create a database, sort, search a database, edit a record etc.	Objectives listed in both general business terms and computer-related terms
3. Description of existing solution	Incomplete description of the current solution	A full description of the current solution, including data input requirements (data capture methods and data dictionary, if applicable) and specifications, the data processing and output requirements and specifications	
4. Evaluation of existing solution	Incomplete evaluation of the current solution	Complete evaluation of the current solution highlighting advantages, disadvantages and any suggested improvement(s)	
5. Description of other possible solutions, (including the proposed solution)	Description of one other possible solution, i.e. the proposed solution	Description of the proposed new solution and at least one other solution	

5. Appendix

DESIGN	1 mark	2 marks	3 marks
6. Action plan, in terms of system life cycle	Incomplete or unclear action plan	Detailed action plan, including time schedule	Detailed formal plan, including a Gantt or PERT chart
7. Systems Flowchart	Correct symbols used for systems flowchart	Complete solution represented in systems flowchart with correct use of symbols	
8. Description of the method of solution	Unclear or confused method of solution	Clear method of solution but some aspects of the method of solution are missing	Clear and detailed description of the method of solution, including database tables, any relationships (Must include annotation or explanation of at least one module of any software generated coding/queries)
9. Hardware	A list of hardware	A detailed specification OR A list of hardware with at least two reasons why such hardware is needed in the context of the proposed solution	A complete list of hardware together with at least two reasons why such hardware is needed in the context of the proposed solution
10. Software	List of software used	Description of the software used	Justification as to why this software is being used or written, e.g. why two facilities are needed from the software

5. Appendix

IMPLEMENTATION	1 mark	2 marks	3 marks
11. Method of solution related to the problem by suitable means, including annotated coding, spreadsheet formulas, database tables, site plans of website	Description of the method of solution described in generic terms	Description of the method of solution described in specific details relevant to the problem	
12. Accurate method of solution	Partly successful, at least one computer-related objective achieved	Partly successful, some of the computer-related objectives achieved as listed previously	Completely successful, all of the previously listed computer-related objectives achieved
13. Programming code	Use macros or pre-written code	Code and annotate own macro(s)	Code and annotate complete solution in any programming language

TESTING	1 mark	2 marks	3 marks	4 marks
14. Test strategy (Must include the expected results)	Incomplete test strategy, which must include the data to be tested together with the expected results	Complete test strategy, which must include the data to be tested together with the expected results	Complete test strategy, which must include the data to be tested together with the expected results and linked to the computer objectives in section 2	
15. Test results (acceptable (normal), unacceptable (abnormal) and boundary (extreme) data)	One type of data tested	Two types of data tested	Three types of data tested	Three types of data tested covering all aspects of functionality (data input and processes)

5. Appendix

DOCUMENTATION	1 mark	2 marks	3 marks
16. Technical documentation	Overall report including contents page but unclear or inadequate documentation	Overall report contents page and clear and complete documentation which would enable maintenance or modification of the system	
17. User guide	Inadequate or unclear details	Clear details but incomplete	Clear and complete user guide

SYSTEM EVALUATION AND DEVELOPMENT	1 mark	2 marks	3 marks
18. Evaluation	Inaccurate or trivial evaluation	Reasonable evaluation	Reasonable evaluation linked to the computer objectives in section 2 and the testing
19. Developments (The candidate does not necessarily have to be capable of carrying out these suggestions)	Some minor improvements suggested	Realistic and meaningful suggestions for development	

The relevant page number(s) should be written underneath the marks awarded for each section on the Individual Candidate Record Card. See section 5.2 of the Appendix for details.

6. Additional information

6.1 Guided learning hours

O Level syllabuses are designed on the assumption that candidates have about 130 guided learning hours per subject over the duration of the course. ('Guided learning hours' include direct teaching and any other supervised or directed study time. They do not include private study by the candidate.)

However, this figure is for guidance only, and the number of hours required may vary according to local curricular practice and the candidates' prior experience of the subject.

6.2 Recommended prior learning

Candidates beginning this course are not expected to have studied Computer Studies or ICT previously.

6.3 Progression

O Level Certificates are general qualifications that enable candidates to progress either directly to employment, or to proceed to further qualifications.

Candidates who are awarded grades C to A* in O Level Computer Studies are well prepared to follow courses leading to AS and A Level Computing, or the equivalent.

6.4 Component codes

Because of local variations, in some cases component codes will be different in instructions about making entries for examinations and timetables from those printed in this syllabus, but the component names will be unchanged to make identification straightforward.

6.5 Grading and reporting

Ordinary Level (O Level) results are shown by one of the grades A*, A, B, C, D or E indicating the standard achieved, Grade A* being the highest and Grade E the lowest. 'Ungraded' indicates that the candidate's performance fell short of the standard required for Grade E. 'Ungraded' will be reported on the statement of results but not on the certificate.

6. Additional information

Percentage uniform marks are also provided on each candidate's statement of results to supplement their grade for a syllabus. They are determined in this way:

- A candidate who obtains...
 - ... the minimum mark necessary for a Grade A* obtains a percentage uniform mark of 90%.
 - ... the minimum mark necessary for a Grade A obtains a percentage uniform mark of 80%.
 - ... the minimum mark necessary for a Grade B obtains a percentage uniform mark of 70%.
 - ... the minimum mark necessary for a Grade C obtains a percentage uniform mark of 60%.
 - ... the minimum mark necessary for a Grade D obtains a percentage uniform mark of 50%.
 - ... the minimum mark necessary for a Grade E obtains a percentage uniform mark of 40%.
 - ... no marks receives a percentage uniform mark of 0%.

Candidates whose mark is none of the above receive a percentage mark in between those stated according to the position of their mark in relation to the grade 'thresholds' (i.e. the minimum mark for obtaining a grade). For example, a candidate whose mark is halfway between the minimum for a Grade C and the minimum for a Grade D (and whose grade is therefore D) receives a percentage uniform mark of 55%.

The uniform percentage mark is stated at syllabus level only. It is not the same as the 'raw' mark obtained by the candidate, since it depends on the position of the grade thresholds (which may vary from one session to another and from one subject to another) and it has been turned into a percentage.

6.6 Resources

Copies of syllabuses, the most recent question papers and Principal Examiners' reports for teachers are available on the Syllabus and Support Materials CD-ROM, which is sent to all CIE Centres.

Resources are also listed on CIE's public website at **www.cie.org.uk**. Please visit this site on a regular basis as the Resource lists are updated through the year.

Access to teachers' forums, suggested schemes of work and regularly updated resource lists may be found on the CIE Teacher Support website at **<http://teachers.cie.org.uk>**. This website is available to teachers at registered CIE Centres.

University of Cambridge International Examinations
1 Hills Road, Cambridge, CB1 2EU, United Kingdom
Tel: +44 (0)1223 553554 Fax: +44 (0)1223 553558
Email: international@cie.org.uk Website: www.cie.org.uk

© University of Cambridge International Examinations 2010